



**HYBRID<sup>2</sup>**



Diesel  
10,6 kW



Inverter actuated  
Electric motor  
16 kW



Lithium iron  
phosphate battery  
LiFePO4 - 16,1 kWh  
(48 V - 315 Ah)

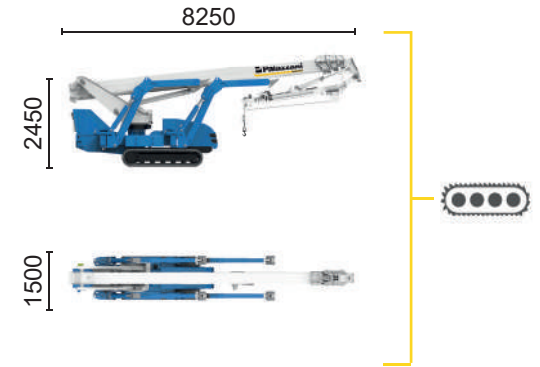
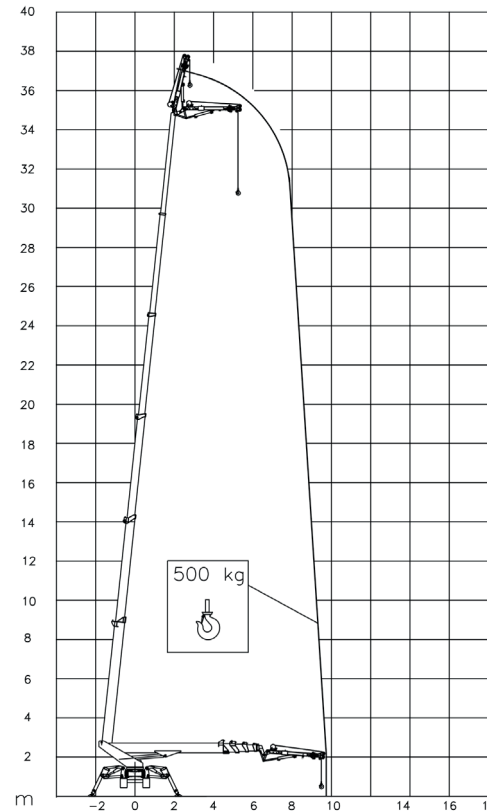

TSJ 39/C  37 m 9,7 m 500 kg 660° 240x70 cm 90°+80° 2,92-4,7 m 18% 40% 2,2 km/h 8100 kg 51 kN 3,47 kN/m<sup>2</sup> 4,09 kN/m<sup>2</sup>

Available power options:

**BI-ENERGY** (DIESEL+AC)

**ECO** (AC+BATTERY)

The technical data may deviate +/- 3% from the specified values.

Characteristics and technical data are informative only and subjected to change without notice.

Palazzani Industrie S.p.A.

Via del Pavione, 4 - 25050 - Paderno F.C. (BS) - Italy

Tel. (+39) 0306857073

info@palazzani.it

www.palazzani.it



NC 931 A 24