

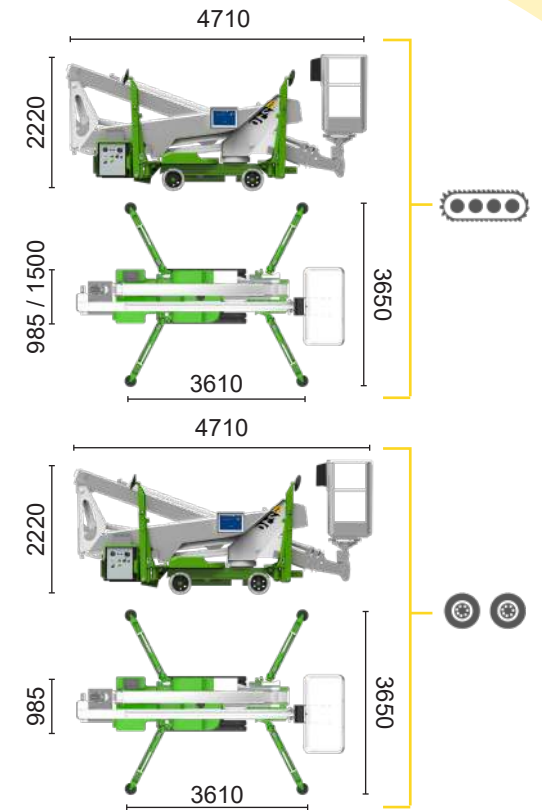

ECO

Inverter actuated
Electric motor

Lithium iron
phosphate battery
LiFePO4

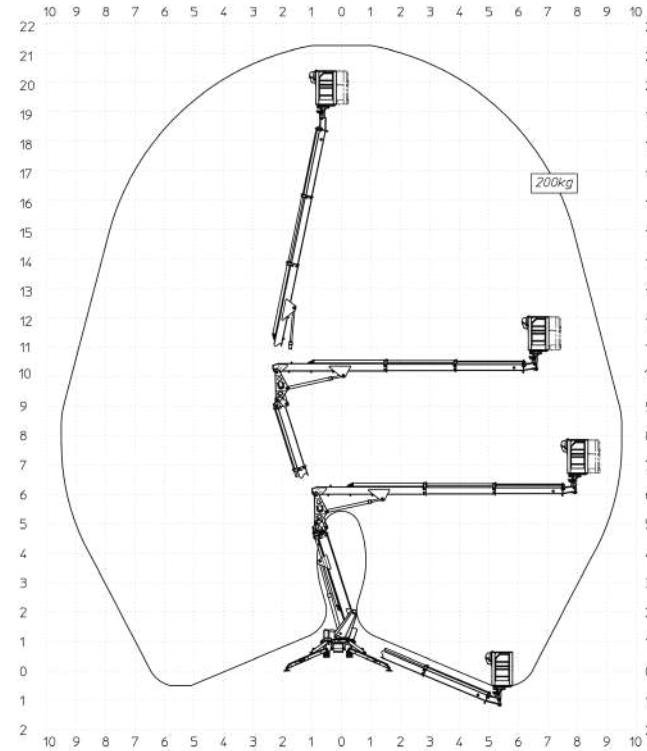

Model	Icon	Height (m)	Width (m)	Weight (kg)	Rotation (°)	Reach (cm)	Reach (°)	Height (m)	Weight (%)	Weight (%)	Speed (km/h)	Capacity (kg)	Capacity (kN)	Capacity (kN/m ²)	Capacity (kN/m ²)
TZX 210/C		21,2 m	9,5 m	200 kg	360°	140x70 cm	90°+90°	3,65 m	21%	23%	2 km/h	2500 kg	19 kN	1,9 kN/m ²	3,79 kN/m ²
TZX 210/R		21,2 m	9,5 m	200 kg	360°	140x70 cm	90°+90°	3,65 m	21%	23%	2 km/h	2500 kg	19 kN	1,9 kN/m ²	3,79 kN/m ²

Available power options:

BI-ENERGY (DIESEL+AC)

The technical data may deviate +/- 3% from the specified values.

Characteristics and technical data are informative only and subjected to change without notice.

Palazzani Industrie S.p.A.

Via del Pavione, 4 - 25050 - Paderno F.C. (BS) - Italy

Tel. (+39) 0306857073

info@palazzani.it

www.palazzani.it



NC 1029 A 25