



**BI-ENERGY**



Diesel  
32,5 kW



Single-phase  
Electric motor  
230 VAC - 2,2 kW



Three-phase  
Electric motor  
400 VAC - 5,5 kW

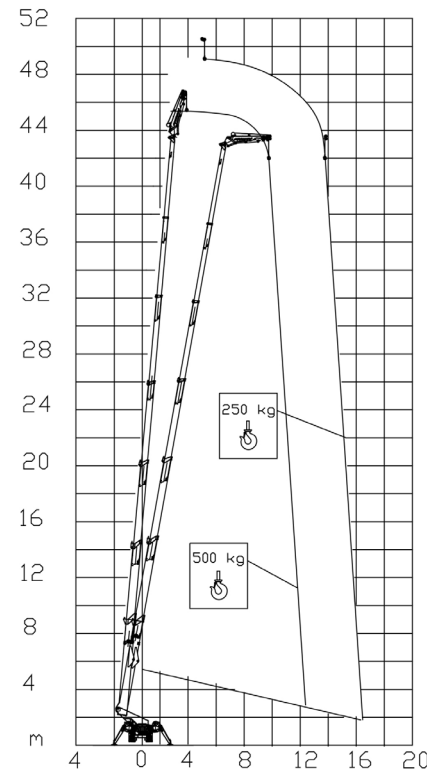

500 kg	250 kg
12,5 m	16,5 m

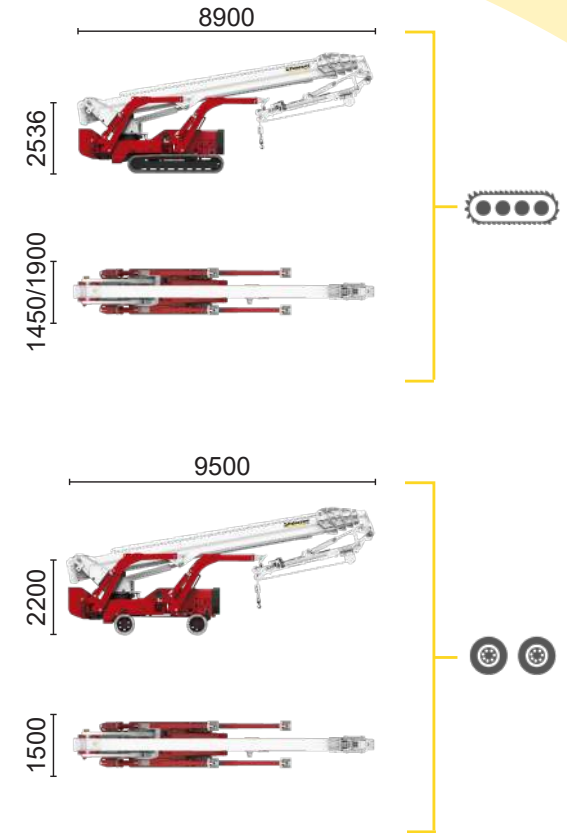

XTJ 52+/C	☹☹☹	49 m	16,5 m	500 kg	660°	240x70 cm	90°+80°	4,13-5,17 m	16%	42%	2 km/h	14980 kg	95 kN	4,48 kN/m <sup>2</sup>	7,01 kN/m <sup>2</sup>
XTJ 52+/R	☺☺	49 m	16,5 m	500 kg	660°	240x70 cm	90°+80°	4,13-5,17 m	16%	21%	1 km/h	14980 kg	95 kN	4,48 kN/m <sup>2</sup>	6,57 kN/m <sup>2</sup>

Available power options:  
**ECO** (AC+BATTERY)

The technical data may deviate +/- 3 % from the specified values.  
Characteristics and technical data are informative only and subjected to change without notice.

Palazzani Industrie S.p.A.  
Via del Pavione, 4 - 25050 - Paderno F.C. (BS) - Italy  
Tel. (+39) 0306857073  
info@palazzani.it  
www.palazzani.it



NC 952 A 24