





ECO

 Inverter actuated
Electric motor
5,5 kW

 Lithium iron
phosphate battery
LiFePO4 - 16,1 kWh
(48 V - 315 Ah)

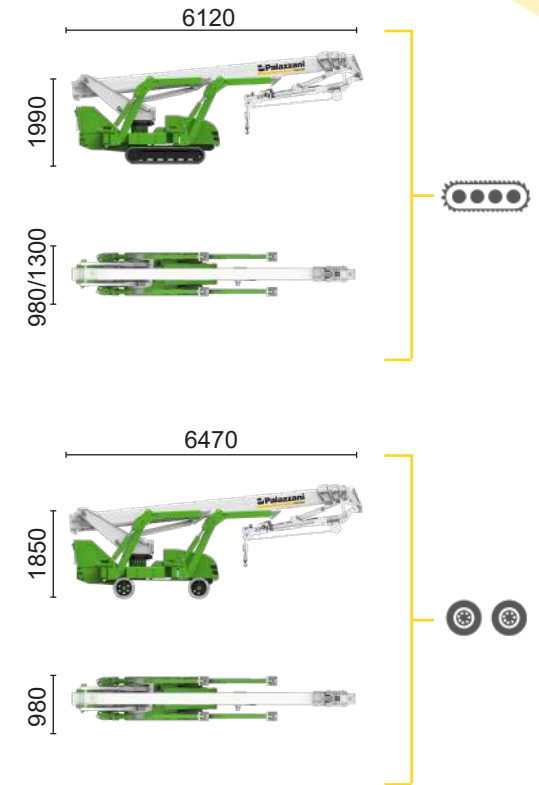
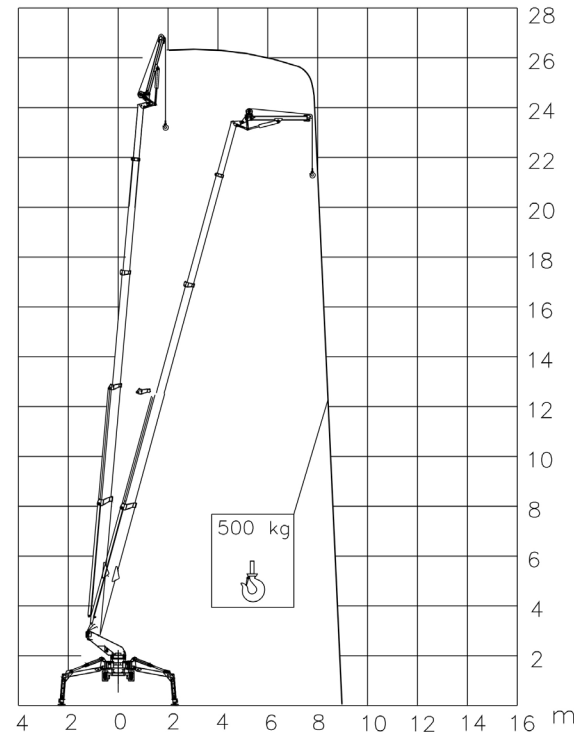

TSJ 27/C		25,5 m	9 m	500 kg	660°	180x70 cm	90°+80°	2,86-4,79 m	44%	42%	1,2 km/h	4455 kg	29 kN	1,89 kN/m ²	4,04 kN/m ²
-----------------	---	--------	-----	--------	------	-----------	---------	-------------	-----	-----	----------	---------	-------	------------------------	------------------------

TSJ 27/R		25,5 m	9 m	500 kg	660°	180x70 cm	90°+80°	2,86-4,79 m	44%	29%	1,2 km/h	4700 kg	29 kN	1,99 kN/m ²	4,04 kN/m ²
-----------------	---	--------	-----	--------	------	-----------	---------	-------------	-----	-----	----------	---------	-------	------------------------	------------------------

Available power options:

BI-ENERGY (DIESEL+AC)

HYBRID (DIESEL+AC+BATTERY)

The technical data may deviate +/- 3% from the specified values.

Characteristics and technical data are informative only and subjected to change without notice.

Palazzani Industrie S.p.A.

Via del Pavione, 4 - 25050 - Paderno F.C. (BS) - Italy

Tel. (+39) 0306857073

info@palazzani.it

www.palazzani.it



NC 911 A 24